

Performance Product Release



BOSCH
Invented for life

F 000 TE1 3X9

High Performance Fuel Pump

Developed under strict production parameters and following the Bosch world quality standard, our Fuel pump was carefully designed to attend the severe demands of performance and modified engines.

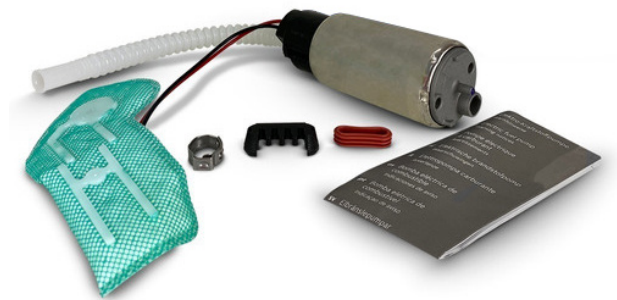

Ideal features to deliver maximum performance to the injection system.

Technical Specifications

Model	In-Tank
Max. Pressure	5 bar / 72,5 psi
Fuel	Gasoline / E100
Bosch Code	F 000 TE1 3X9

Kit Composition: Fuel Pump, Tube, Pre-Filter and Wire Harness

Model (out of scale / dimensions in mm)

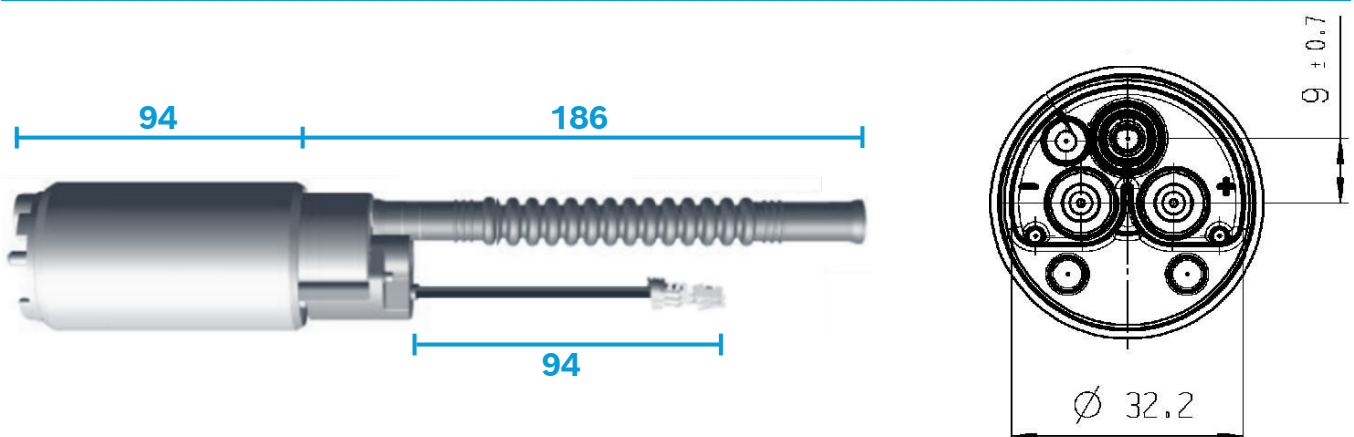

Flow x Pressure

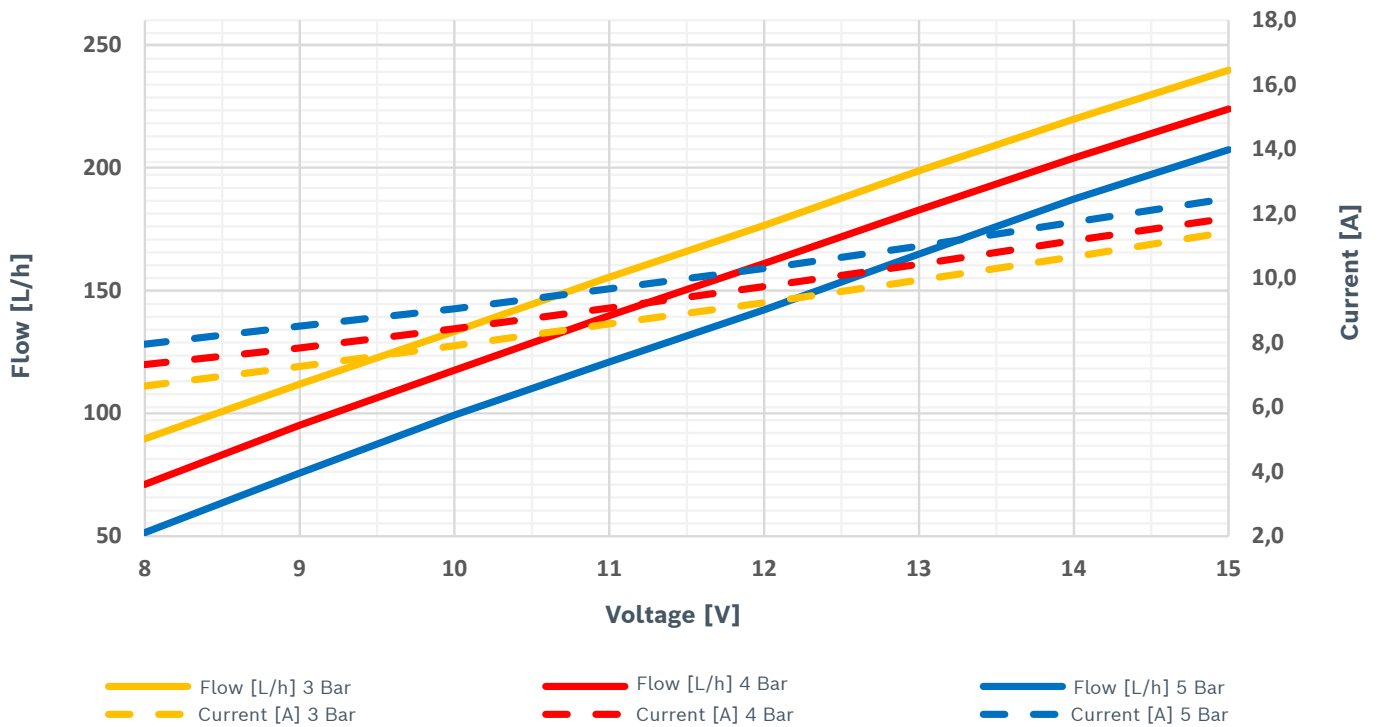

Pressure		Voltage [V]					
		12		13		14	
[bar]	[psi]	Flow [L/h]	Current [A]	Flow [L/h]	Current [A]	Flow [L/h]	Current [A]
3,0	43,5	176	9,2	199	9,9	220	10,7
3,5	50,8	168	9,5	190	10,3	211	11,0
4,0	58,0	161	9,7	183	10,4	204	11,2
4,5	65,3	152	9,9	173	10,6	195	11,3
5,0	72,5	142	10,3	165	11,0	187	11,7